

VIBRATING SCREEN FOR POWDER

VBA 600-800

TECHNICAL FEATURES

DATA	U.M.	600	800
Power	kW	0.48	0.48
Centrifugal force	N	4.121	5,886
Number screening nets	No.	1	
Screening surface	sq.m	0.264	0.36
Motorised vibrator	Type	MV 112/2	MV 116/2
Weight	kg	125	135

STRUCTURAL FEATURES

- Self-supporting structure, ready to be fastened to the press-feeding hopper.
- Tilted flat bottom.
- Fully automatic and independent operation.

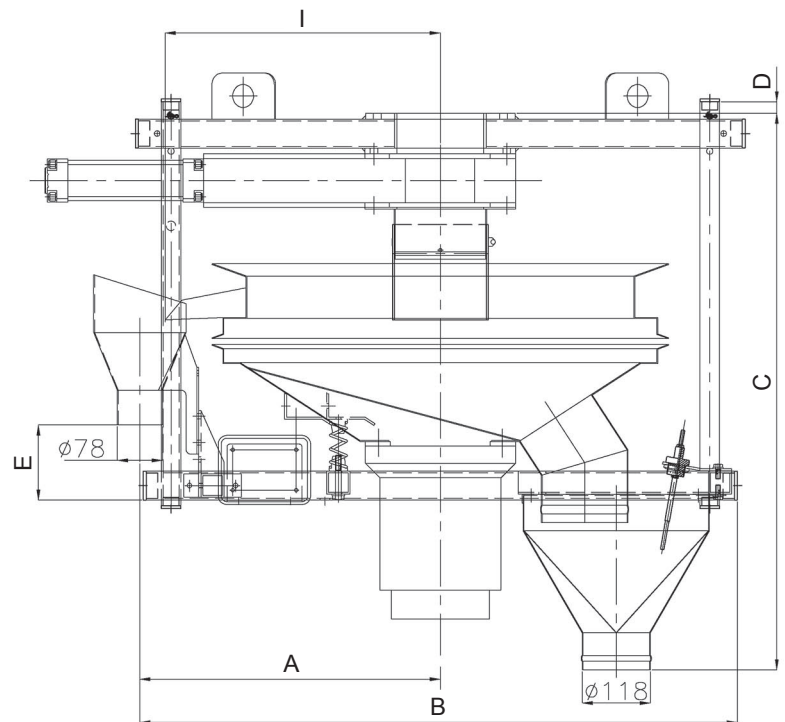
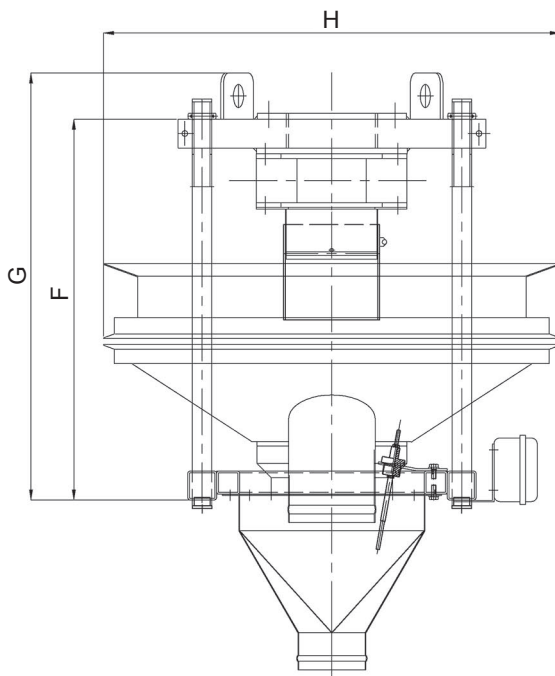

Mod./Size	A	B	C	D	E	F	G	H	I
600	441	956	905	80	55	600	680	670	385
800	521	1,036	965	20	130	660	740	792	483

USE

- Press supply atomised powder screening.

ACCESSORIES

- Mesh cleaning system.

The information is approximate - The guaranteed values are released by Vibrotech s.r.l. on request-It is forbidden to reproduce the document even partially.