

VIBRATING SCREEN FOR POWDER

VBA 900-1200

TECHNICAL FEATURES

DATA	U.M.	900	1200
Power	kW	0.73	1.25
Centrifugal force	N	8.330	12.740
Number screening nets	No.	1	
Screening surface	sq.m	0.587	0.932
Motorised vibrator	Type	MV 125/4	MV 145/4
Weight	kg	290	360

STRUCTURAL FEATURES

- Self-supporting structure, ready to be fastened to the press-feeding hopper.
- Tilted flat bottom.
- Fully automatic and independent operation.

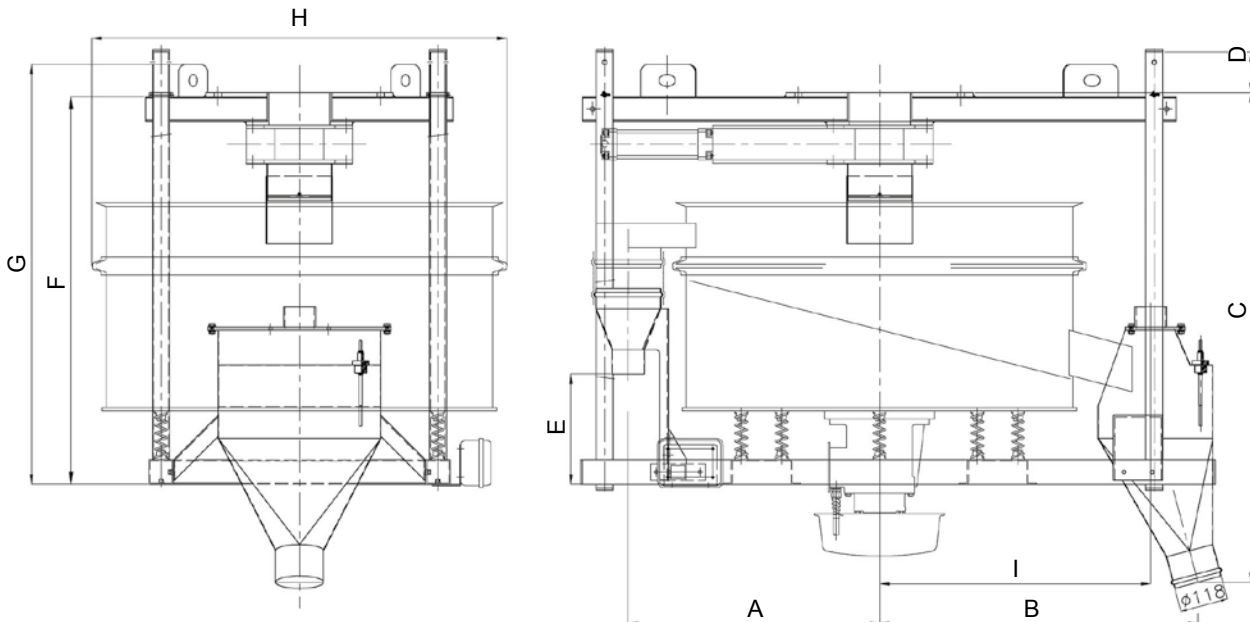

Mod./Size	A	B	C	D	E	F	G	H	I
900	617	782	1.200	100	270	950	1.030	1.020	790
1200	724	906	1.280	20	312	1.030	1.110	1.205	667

USE

- Press supply atomised powder screening.

ACCESSORIES

- Mesh cleaning system.

The information is approximate - The guaranteed values are released by Vibrotech s.r.l. on request-It is forbidden to reproduce the document even partially.