

VIBRATING SCREEN FOR POWDER

VBP 500 - 800 1X

TECHNICAL FEATURES

DATI	U.M.	500	800
Number screening nets	N.	1	1
Screening surface	m ²	0,20	0,36
Power	kW	0,44	0,48
Centrifugal force	N	3000	5886
Vibrator motor	Type	MV 116/4	MV 116/4
Weight	Kg	70	105

STRUCTURAL FEATURES

- Completely in steel AISI 304
- Compact and handy
- Motorised vibrator with long life lubrication
- Practical and handy mesh replacement system

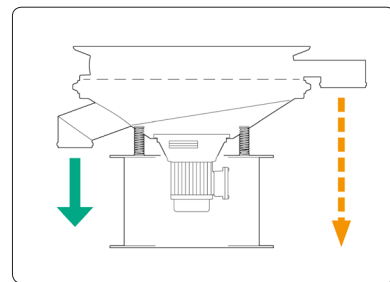
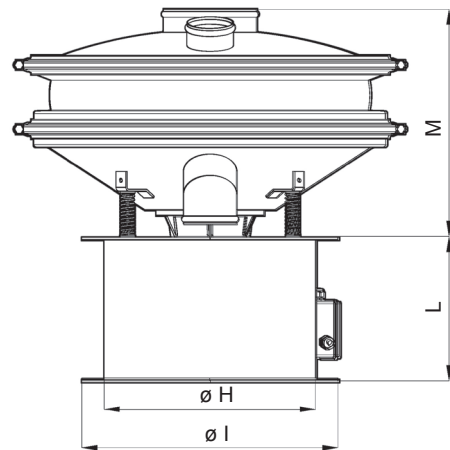
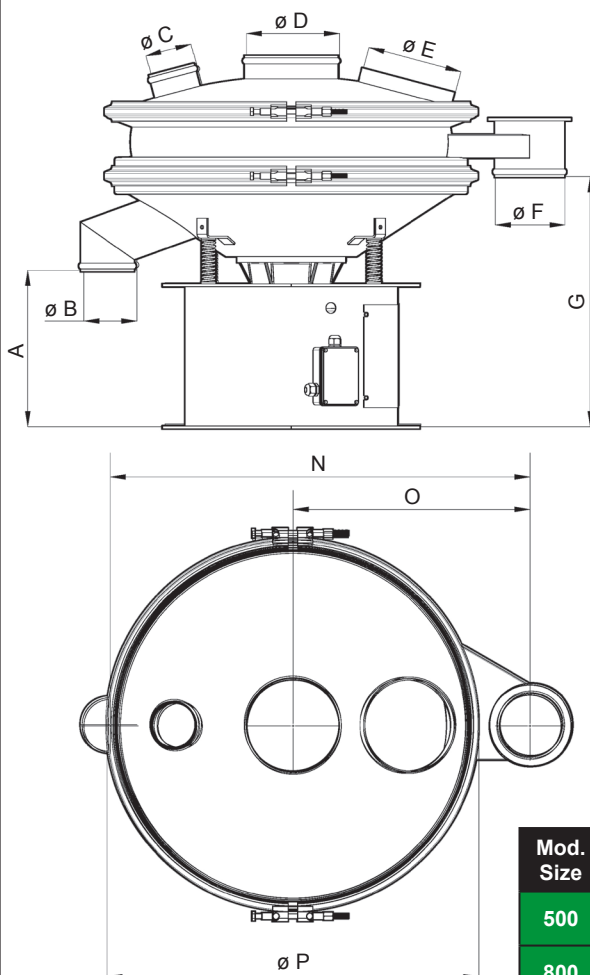

Mod. Size	A	øB	øC	øD	øE	øF	G	øH	øI	L	M	N	O	øP
500	336	98	80	150	150	120	538	364	460	310	448	718	405	600
800	336	114	100	200	200	150	538	454	550	310	488	903	510	800

USE

- Fine powder screening
- Available for liquid screening

ACCESSORIES AND VERSIONS

- Dust protection cover with inspection door and suction intake
- Several systems for screening nets automatic unclogging
- Carriage with fixed base or wheels
- Food version with FDA certifications

The information is approximate - The guaranteed values are released by Vibrotech s.r.l. on request - It is forbidden to reproduce the document even partially.