

VIBRATING SCREEN FOR POWDER AND LIQUIDS

VB2 800 - 900 - 1200 - 1500 1/X

TECHNICAL FEATURES

DATA	U.M.	800	900	1200	1500
Number screening nets	no.	1			
Screening surface	m ²	0.360	0.587	0.932	1.575
Power	kW	0.3+0.3	0.62+0.62	0.62+0.62	0.9+0.9
Centrifugal force	N	8378	13165	13165	27566
Motorised vibrator	Type	MVE 400	MVE 700	MVE 700	MVE 1400
Weight	kg	150	190	280	490

STRUCTURAL FEATURES

- Open base with discharge outlet connected to the power feed.
- Lateral motor vibrators, IP65 protection rating, certified ATEX zone 22
- Parts in contact with product: AISI 304 stainless steel
- RAL 7035 painted carbon steel frame

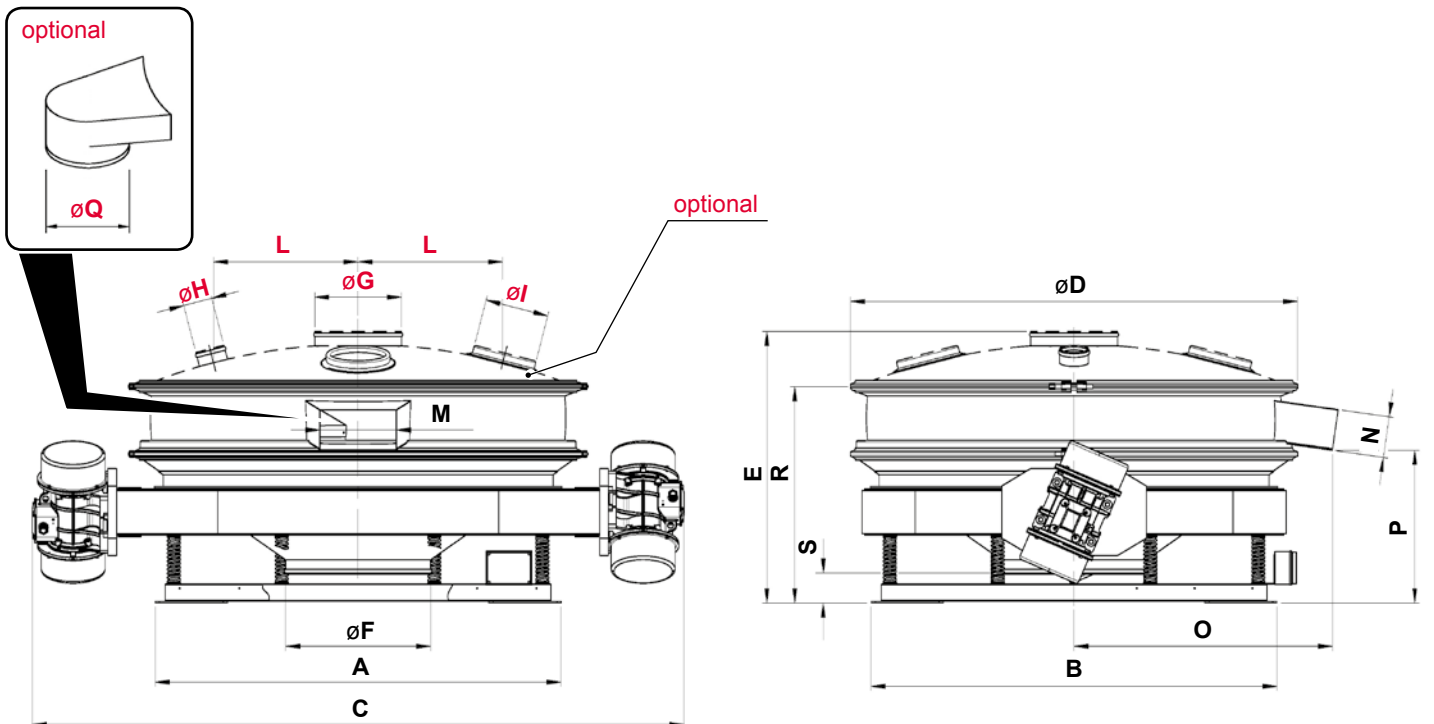

Mod./Size	A	B	C	∅D	E	∅F	∅G	∅H	∅I	L	M	N	O	P	∅Q	R	S
800 1/X	740	839	1365	800	510	300	200	100	1X200	244	140	30	510	260	150	397	55
900 1/X	857	970	1490	992	704	400	200	100	1X200	275	140	30	608	429	160	573	159
1200 1/X	1039	1180	1708	1210	853	400	200	100	2X200	420	265	140	725	473	160	691	126
1500 1/X	1403	1403	2253	1550	937	500	300	100	3X200	500	265	140	893	527	200	745	98

USE

- Powder screening
- Sprayer discharge outlet
- Press feed
- Mill discharge outlet

The information is approximate - The guaranteed values are released by Vibrotech s.r.l. on request-It is forbidden to reproduce the document even partially.