

VIBRATING SCREEN FOR POWDER

VBP 900 - 1200 - 1500 - 2000 2X

TECHNICAL FEATURES

DATI	U.M.	2000	1500	1200	900
Number screening nets	n.	2			
Screening surface	m ²	2,7+ 2,7	1,575+1,575	0,932+0,932	0,587+0,587
Power	kW	5	2,75	1,25	0,73
Centrifugal force	N	58.800	24.500	12.740	8.330
Vibrator motor	Tipo	Z8	MV155/4	MV145/4	MV125/4
Weight	kg	950	520	275	195

STRUCTURAL FEATURES

- AISI 304 stainless steel base, with ABS inspection door
- Parts in contact with the product: AISI 304 L – roughness ≤ 0.5 Ra μ
- Protection rating: IP65
- Sifted product outfeed: with sloping surface
- Clamping system: half-rings with bolts

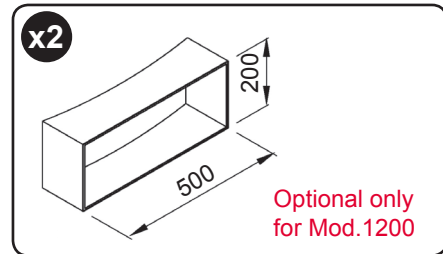
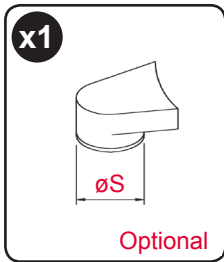
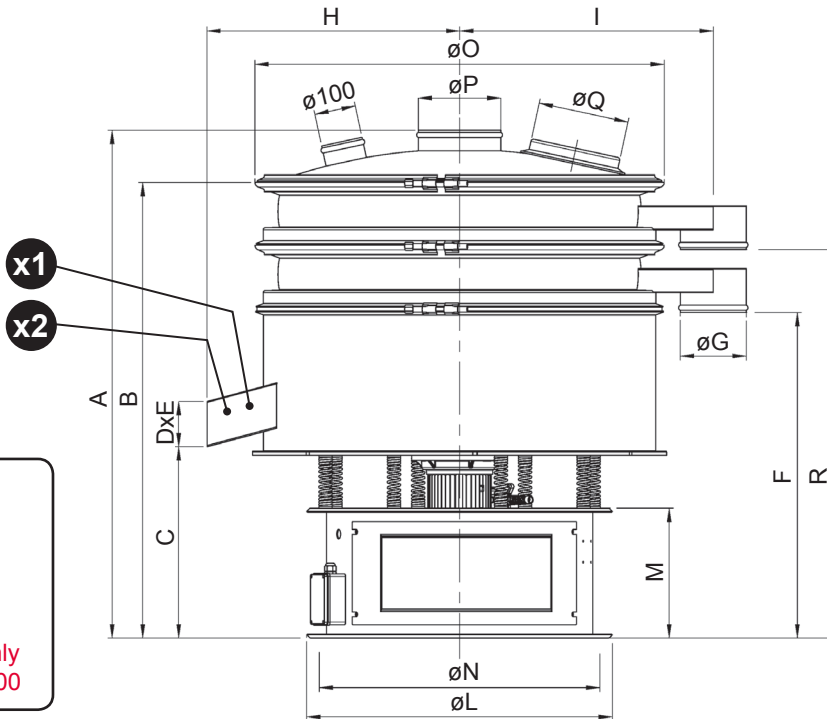

Mod./Size	A	B	C	D	E	F	ØG	H	I	ØL	M	ØN	ØO	ØP	ØQ	ØR	ØS
900 2/X	1232	1105	464	110	260	790	160	626	615	741	315	680 N.4 fori Ø11 a 90°	996	200	1x200	942	200
1200 2/X	1378	1217	472	110	260	837	160	738	727	741	315	680 N.4 fori Ø11 a 90°	1210	200	2x200	1201	200
1500 2/X	1599	1410	603	200	500	1013	200	937	925	937	380	870 N.4 fori Ø11 a 90°	1550	300	3x200	1197	300
2000 2/X	1817	1637	685	200	600	1238	200	1200	1160	1260	515	1215 N.4 fori Ø18 a 90°	1973	300	3x200	1428	300

USE

- Screening powder and granules in general

ACCESSORIES AND VERSIONS

- Mesh self-cleaning system with balls or cleaning rings
- Dust protection cover with inspection door and diffuser
- Sloping surface coating with Teflon or polyurethane
- Round discharge outlets

The information is approximate - The guaranteed values are released by Vibrotech s.r.l. on request - It is forbidden to reproduce the document even partially

