

VIBRATING SCREEN FOR POWDER

VBP 500 - 800 2X

TECHNICAL FEATURES

DATA	U.M.	500	800
Number screening nets	N.	2	2
Screening surface	m ²	0,20+0,20	0,36+0,36
Power	kW	0,48	0,48
Centrifugal force	N	3000	5886
Vibrator motor	Type	MV 116/4	MV 116/4
Weight	kg	80	115

STRUCTURAL FEATURES

- Completely in steel AISI 304
- Compact and handy
- Motorised vibrator with long life lubrication
- Practical and handy mesh replacement system

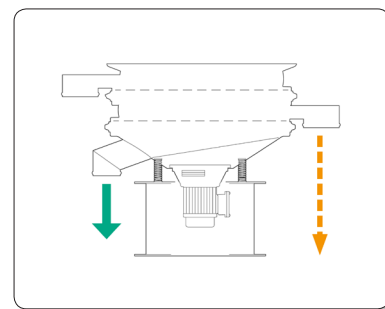
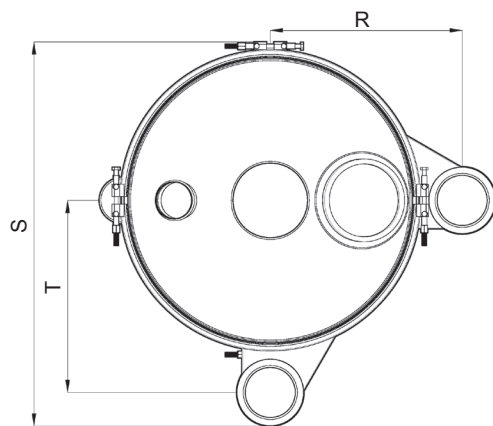
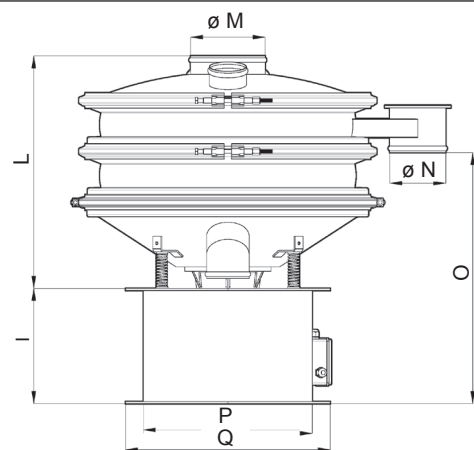
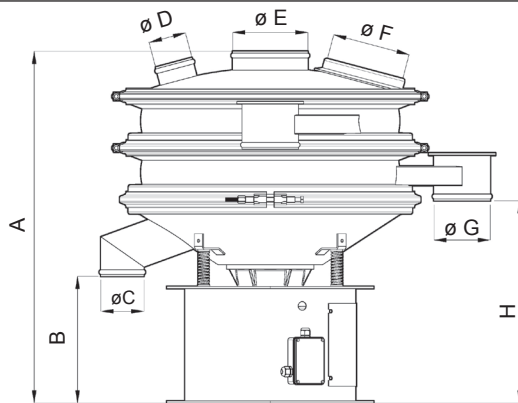

Mod. Size	A	B	øC	øD	øE	øF	øG	H	I	L	øM	øN	O	P	Q	R	S	T
500	902	336	98	80	150	150	120	538	310	592	150	120	674	364	460	405	785	405
800	934	336	114	100	200	200	150	538	310	624	200	150	674	454	550	510	1020	510

USE

- Fine powder screening
- Available for liquid screening

ACCESSORIES AND VERSIONS

- Dust protection cover with inspection door and suction intake
- Several systems for screening nets automatic unclogging
- Carriage with fixed base or wheels
- Food version with FDA certifications

The information is approximate - The guaranteed values are released by Vibrotech s.r.l. on request - It is forbidden to reproduce the document even partially.