

**VIBRATING SCREEN FOR POWDER**

**VBP 900 - 1200 - 1500 - 2000 1X**

**TECHNICAL FEATURES**

DATA	U.M.	2000	1500	1200	900
Number screening nets	No.	1			
Screening surface	m <sup>2</sup>	2.7	1.575	0.932	0.587
Power	kW	5	2.75	1.25	0.73
Centrifugal force	N	58800	24500	12740	8330
Vibrator motor	Type	Z8	MV155/4	MV145/4	MV125/4
Weight	kg	850	450	250	175

**STRUCTURAL FEATURES**

- AISI 304 stainless steel base, with ABS inspection door
- Parts in contact with the product: AISI 304 L – roughness ≤ 0.5 Ra $\mu$
- Protection rating: IP65
- Sifted product outfeed: with sloping surface
- Clamping system: half-rings with bolts

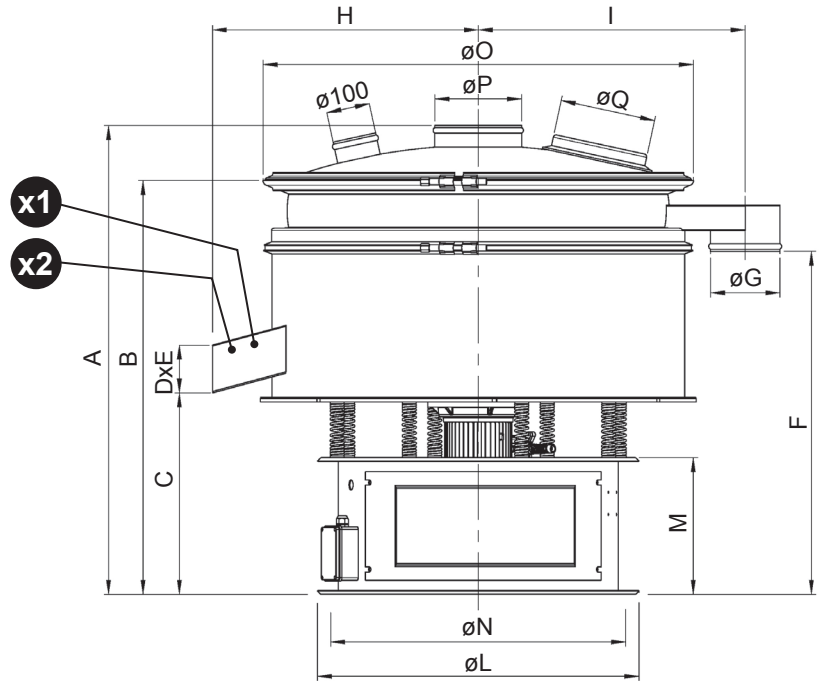
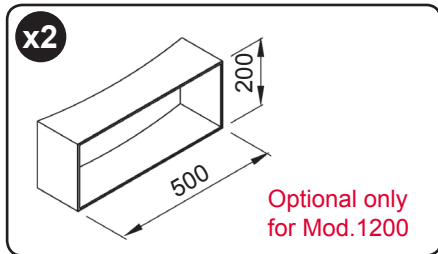
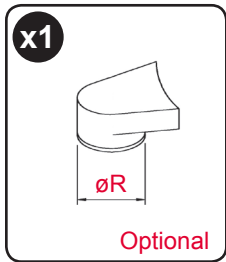

Mod./Size	A	B	C	D	E	F	$\varnothing G$	H	I	$\varnothing L$	M	$\varnothing N$	$\varnothing O$	$\varnothing P$	$\varnothing Q$	$\varnothing R$
<b>900 1/X</b>	1079	953	464	110	260	790	160	626	615	741	315	680 N.4 fori $\varnothing 11$ a 90°	996	200	1x200	200
<b>1200 1/X</b>	1194	1034	472	110	260	837	160	738	727	741	315	680 N.4 fori $\varnothing 11$ a 90°	1210	200	2x200	200
<b>1500 1/X</b>	1415	1226	603	200	500	1013	200	937	925	937	325	870 N.4 fori $\varnothing 11$ a 90°	1550	300	3x200	300
<b>2000 1/X</b>	1627	1447	685	200	600	1238	200	1200	1160	1260	515	1215 N.4 fori $\varnothing 18$ a 90°	1973	300	3x200	300

**USE**

- Screening powder and granules in general

**ACCESSORIES AND VERSIONS**

- Mesh self-cleaning system with balls or cleaning rings
- Dust protection cover with inspection door and diffuser
- Sloping surface coating with Teflon or polyurethane
- Round discharge outlets

The information is approximate - The guaranteed values are released by Vibrotech s.r.l. on request - It is forbidden to reproduce the document even partially.