

## VIBRATING SCREEN FOR CASTING SLIP

VBL 900 - 1200 - 1500 1/X

## TECHNICAL FEATURES

| DATA                  | U.M.           | 1500     | 1200     | 900      |
|-----------------------|----------------|----------|----------|----------|
| Number screening nets | no.            | 1        |          |          |
| Screening surface     | m <sup>2</sup> | 1.575    | 0.932    | 0.587    |
| Power                 | kW             | 2.75     | 1.25     | 0.73     |
| Centrifugal force     | N              | 21,582   | 12,753   | 6,867    |
| Motorised vibrator    | Type           | MV 155/4 | MV 145/4 | MV 125/4 |
| Weight                | kg             | 230      | 145      | 105      |

## STRUCTURAL FEATURES

- AISI 304 stainless steel base, with ABS inspection door
- Parts in contact with the product: AISI 304 L – roughness  $\leq 0.5 \text{ Ra}$
- Protection rating: IP65
- Upper anti-splash strip
- Clamping system: half-rings with bolts
- Galvanised steel diffuser with PA cone

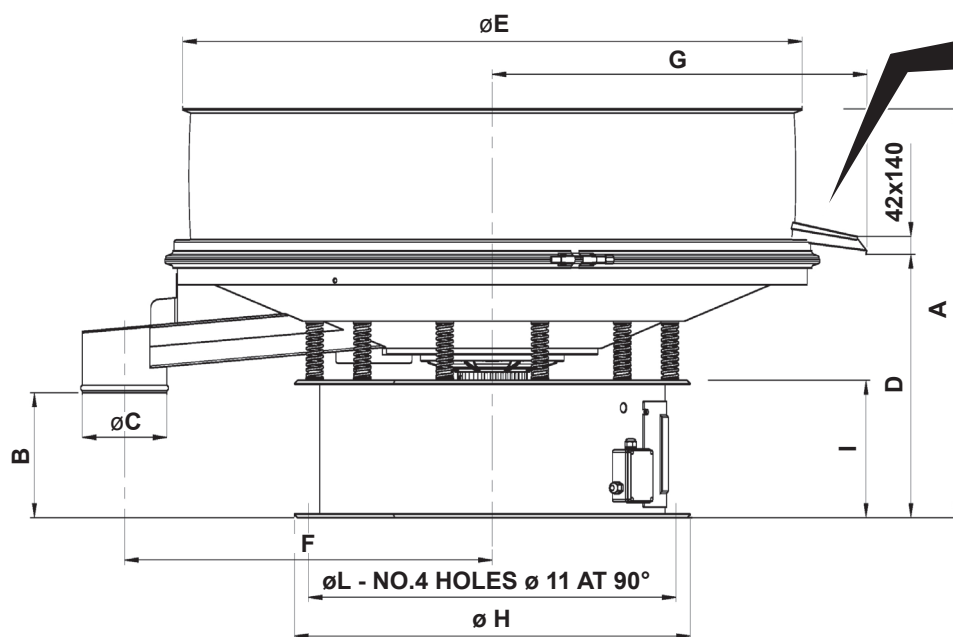
Cylindrical version  
discharge

optional

| Mod./Size | A    | B   | øC    | D   | øE   | F   | G   | øH  | I   | øL  | øM  |
|-----------|------|-----|-------|-----|------|-----|-----|-----|-----|-----|-----|
| 900 1/X   | 817  | 298 | 101.6 | 526 | 911  | 525 | 608 | 741 | 315 | 680 | 160 |
| 1200 1/X  | 915  | 319 | 139.7 | 571 | 1125 | 587 | 715 | 741 | 315 | 680 | 160 |
| 1500 1/X  | 1077 | 406 | 200   | 733 | 1465 | 870 | 889 | 937 | 380 | 870 | 200 |

## USE

- Screening of ceramic casting slips

## ACCESSORIES AND VERSIONS

- Quick-coupling diffuser, protected against incrustations

The information is approximate - The guaranteed values are released by Vibrotech s.r.l. on request-It is forbidden to reproduce the document even partially.